

INCRA[®] Fence System designed for the INCRA[®] Jig Incremental Positioning

Owner's Manual

Please read this Owner's Manual before use and keep it at hand for reference.

From simple routing operations such as edge forming, grooving, dadoing, or rabbeting, to high quality joinery, your new INCRA Fence System and Right Angle Fixture combined with the INCRA Jig Positioner will provide an unlimited source of precision and satisfaction for all your router table projects. The T-slot design of the Fence and Right Angle Fixture permit the easy addition of user made sub fences and auxiliary faceplates for specialty applications. Durable aluminum construction and double laminated Fence and Stop ensure reliable performance for years to come.

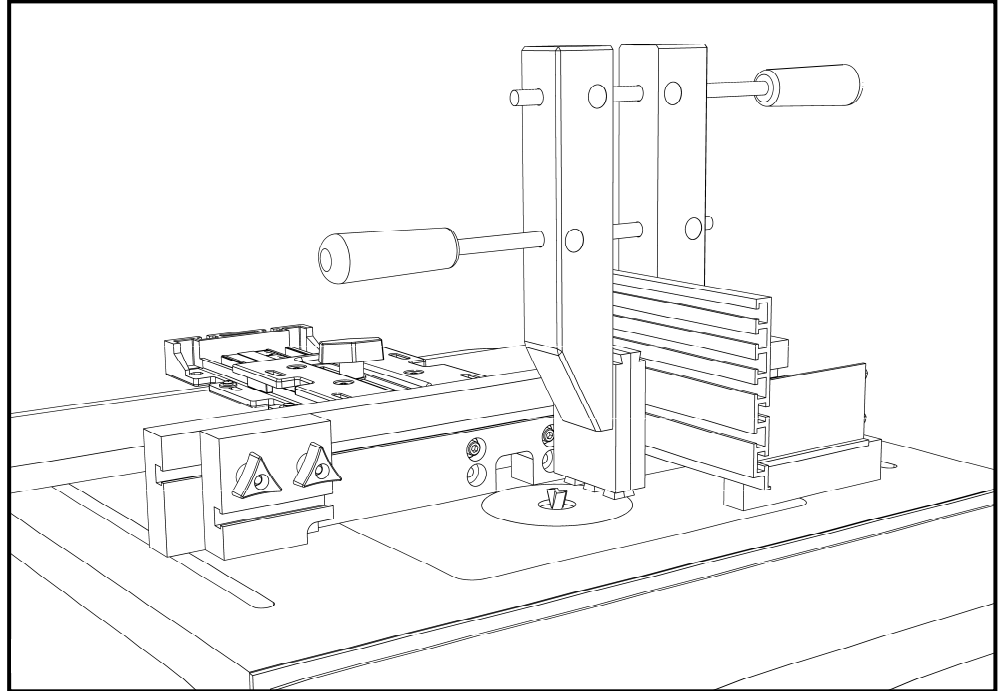

SAFETY Important safety instructions for using the INCRA Fence System

- Before using the INCRA Fence System and Right Angle Fixture, carefully read and follow all of the instructions and safety information in this manual.
- Always turn off the power and make sure that the bit or blade is fully stationary before moving any component of the INCRA Fence System to any new setting.
- When using the INCRA Fence System and Right Angle Fixture with any other tools, make sure that all safety guards and other safety equipment supplied by the manufacturer of that tool are securely in place and functional
- Never let any part of the INCRA Fence System or Right Angle Fixture interfere with another tool's safety guards or other safety equipment.
- Use appropriate safety devices. Keep hands clear of the bit or blade. Always use a push stick, rubber soled push block, or other safety devices to keep your hands safely away from the cutting tool.
- Never let the bit or blade come in contact with the aluminum body of the INCRA Right Angle Fixture.
- Never attempt to hold your work to the INCRA Right Angle Fixture using your hands alone. Always use a clamp or other suitable holding device to securely hold your work to the front face of the fixture.
- Never let the bit or blade come in contact with the wooden runners on your INCRA Right Angle Fixture. Always clamp a wooden stop to the outfeed end of the fence to stop the forward motion of the Right Angle Fixture before the bit contacts the wooden runners.

INCRA[®]
www.incra.com

Made in America by:
Taylor Design Group, Inc.
PO Box 810262
Dallas, TX 75381
Phone: 972-242-9975

INCRA Products are protected by the following US Patents: #4,793,604, #4,930,221, #5,195,730, #5,725,074, #5,423,360, #5,716,045, #6,237,457, #6,557,601, #6,672,190
Other patents granted or pending.

INCRA Fence & Stop - Assembly and Use

Step 1. Attach the INCRA Jig to your router table.

The INCRA Fence System is designed to work as the “front end” to the INCRA Jig Positioner, so the first step is to attach your INCRA Jig to your router table. After following the instructions in the INCRA Jig owner’s manual for attaching your INCRA Jig to a wooden base panel, use C-clamps to attach the base panel to your router table as shown in **Fig. 1**. If your router table is “INCRA-ready” with built-in mounting slots, you can use the bolt, washer and knob combination shown in **Fig. 1A** for maximum versatility and ease of use.

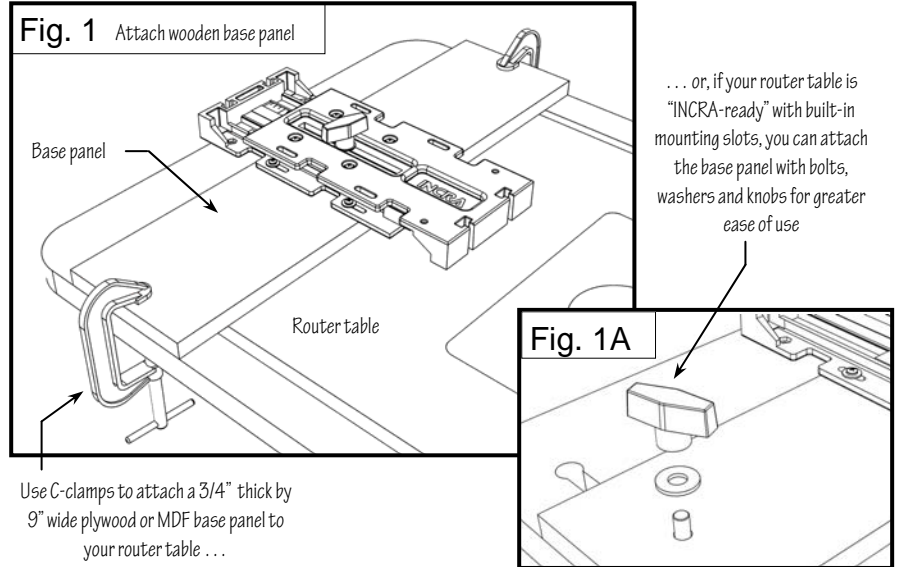

Step 2. Attach the INCRA Fence to the INCRA Jig

Open **hardware pack D-03**. Place a washer on each of the (2) 1/4-20 x 1 1/4" socket head fasteners and insert through the upper holes on the fence. Now loosely thread on the 1/4-20 rectangular nuts. **CAUTION: The raised rim on the two rectangular nuts MUST FACE AWAY from the fence, as shown in Fig. 2.** Lower the rectangular nuts into the T-slots located on the front end of the INCRA Jig, then tighten the fasteners using the included 3/16" hex key.

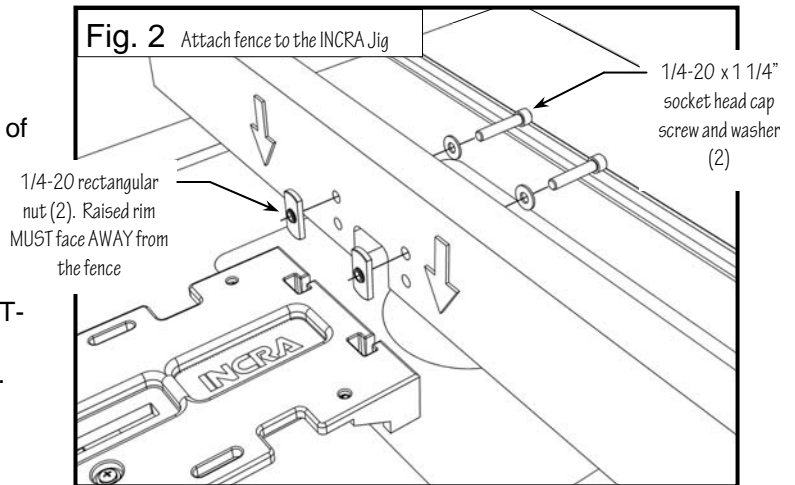

Step 3. Square fence to router table.

After attaching your fence to the INCRA Jig, check for squareness with your router table top. If any adjustment is necessary, loosen the fence mounting screws and insert a paper or plastic shim between the INCRA Jig and the rear face of the fence, **Fig. 3**. A shim placed *below* the fasteners will increase the angle between the fence and the table. A shim placed *above* the fasteners will decrease the angle. Tighten the fasteners to secure the fence.

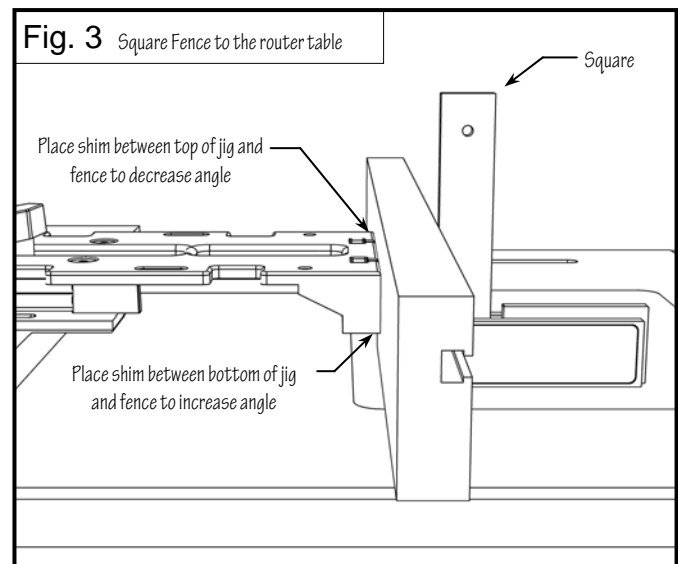

Step 4. Assemble and attach stop positioner.

To assemble the stop positioner, insert the (2) 1/4-20 x 1 3/4" hex bolts from **hardware pack D-03** through the holes on the stop. Add the two washers and loosely attach the 1/4-20 thumb knobs. Now slide the hex bolt heads into the T-slot on the outfeed end of the INCRA Fence, **Fig. 4**. Position the stop as needed, and tighten the thumb knobs before use.

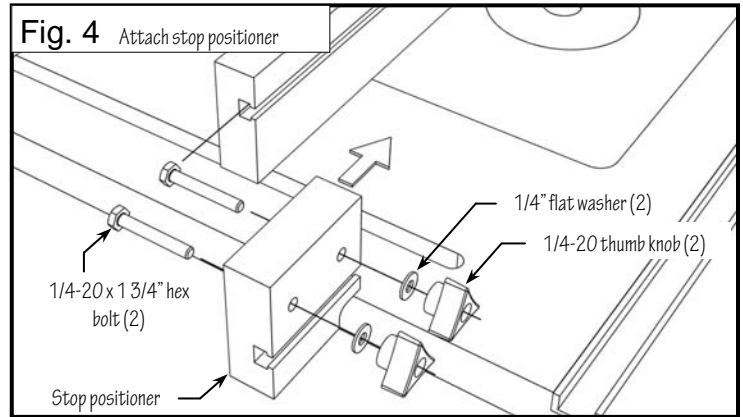

Using the stop positioner.

Use the stop positioner to limit the length of cuts made with your INCRA Fence System. The cutaway notch permits the stop to be positioned safely inside your cutter's diameter for applications such as dovetail pin cuts shown in **Fig 5**.

TIP: The un-notched end of the stop can also be used for the stopping surface by simply rotating the stop 180 degrees before attaching it to the fence's T-slot.

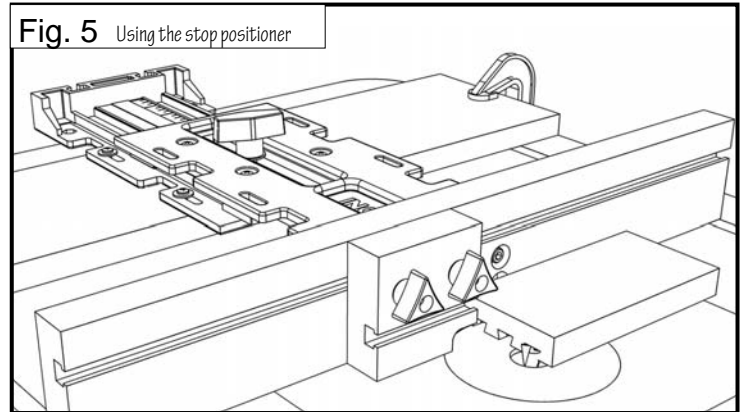

TIP: Marking the stop's position before making fine adjustments.

When making fine adjustments relative to an initial stop position, place a reference mark on the front face of the fence along the leading edge of the stop positioner, **Fig 6**. Now, when you loosen the thumb knobs to reposition the stop, you can easily gauge how much you have moved the positioner. After use, the pencil mark is easily wiped off the hard laminate surface on the front face of the fence.

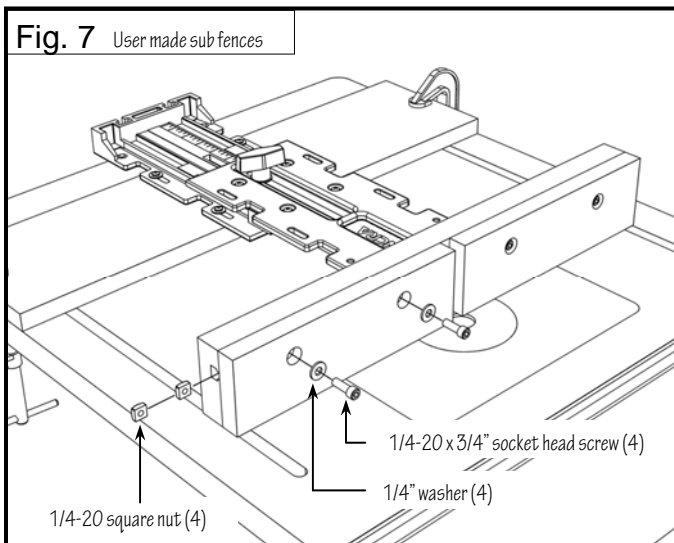
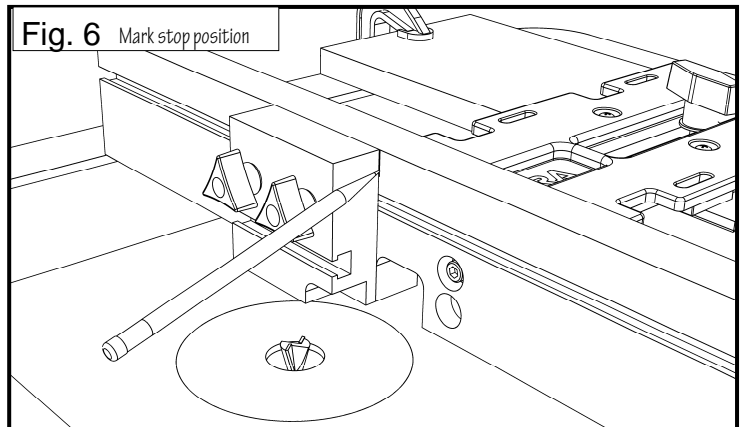

User made sub fences.

User made sub fences for variable gap width and zero clearance applications can be attached to the T-slot on the front of the fence. Just cut to size, drill and counter bore the MDF or plywood fences, using the dimensions shown in **Fig 7A**. You can attach sub fences up to 3/4" thick with the 1/4-20 x 3/4" socket head cap screws, washers and square nuts supplied in **hardware pack D-04**, **Fig. 7A**.

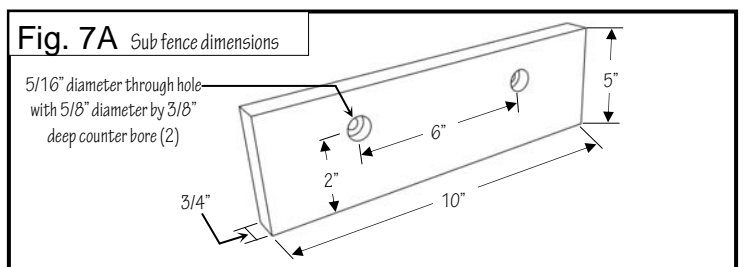

INCRA Right Angle Fixture - Assembly and Use

Step 1. Attach faceplate to base.

Attach the INCRA Right Angle Fixture faceplate to the INCRA Right Angle Fixture base using the (4) supplied 10-32 x 5 1/2" hex bolts and rectangular nuts. Insert the bolts through the four holes in the base and loosely attach the (4) rectangular nuts. Now slide the T-slots on the back of the faceplate over the rectangular nuts, **Fig. 8**. Make sure the two surfaces marked with an "x" in **Fig. 8A** are aligned flush, then securely tighten the hex bolts.

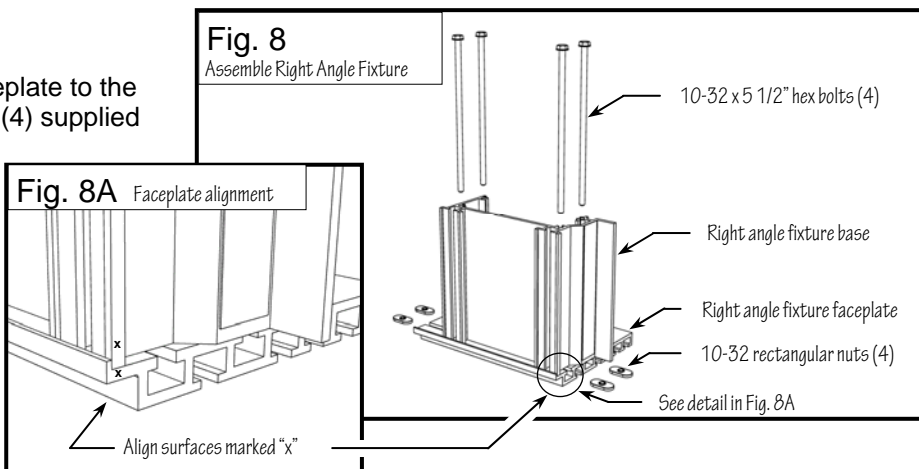

Step 2. Attach wooden runners.

Attach the two wooden runners to the bottom of your Right Angle Fixture base using the (4) 10-32 x 1 1/4" Phillips screws, washers and hex nuts as shown in **Fig. 9**. Each runner should extend about 1/2" beyond the rear of the base.

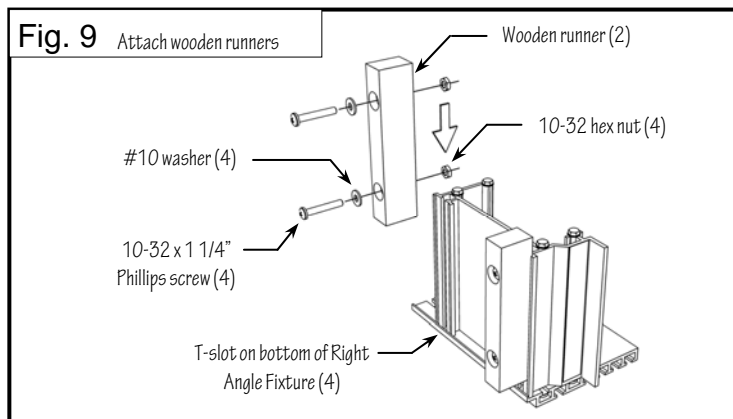

Right Angle Fixture operation.

Before clamping a work piece to your Right Angle Fixture, always press the fixture against your fence, then immobilize by clamping it to the table with a spring clamp, **Fig. 10**. When positioning the work piece against the faceplate, make sure that the edges of the boards are against the fence and the ends are contacting the table surface, then clamp in place using a wooden handscrew clamp.

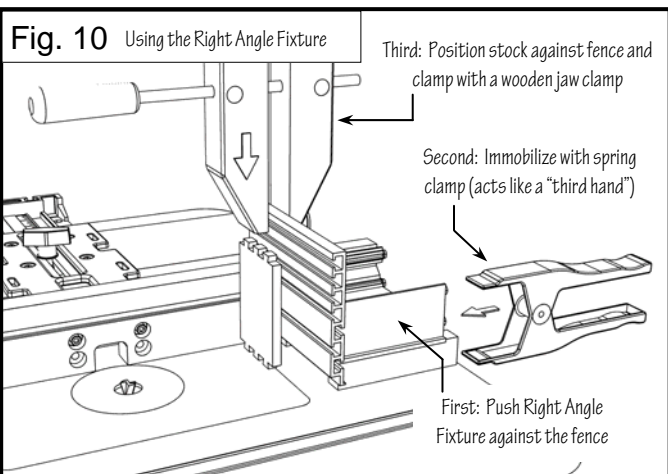

CAUTION: Do not allow any part of your hands to hang below the aluminum body of the Right Angle Fixture. Always keep hands well away from the bit.

To avoid contacting the wooden runners with the router bit, clamp a wooden stop block to the outfeed end of the fence to stop the forward travel before contact, **Fig. 11**.

